

Features

- Compact, 3-ported valves have oversized orifice for quick exhaust of cylinders, brakes, actuators, clutches, etc.
- Allow use of smaller pipe lines and control components
- When used as a shuttle valve, high pressure from the two inlets exits through the common outlet
- Mountable in any position

Construction

Valve Parts in Contact with Fluids	
V043 051	
Body and Bonnet	316 Stainless Steel
Seat	HYT
All Others	
Body and Bonnet	Die-Cast Zinc
Seat	NBR

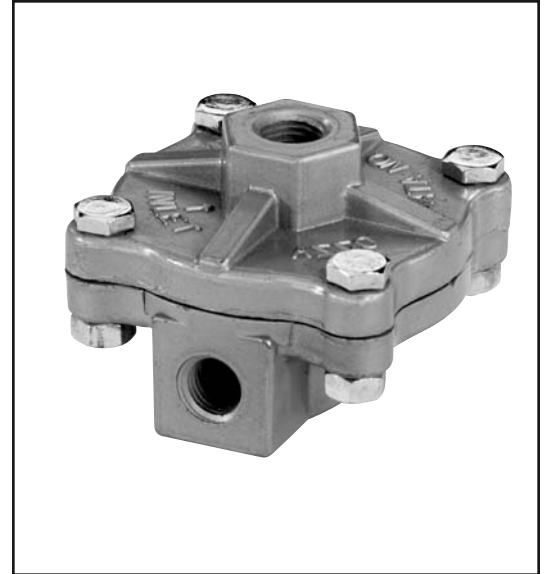

Nominal Ambient Temp. Ranges

V043 051: -40°F to 125°F (-40°C to 52°C)

All Others: -4°F to 125°F (-20°C to 52°C)

Refer to Engineering Section for details.

Specifications (English units)

Pipe Size (ins.)	Cv Flow Factor		Opening Pressure (psi)	Maximum Operating Pressure Differential (psi)	Max. Air Temp. °F	Quick Exhaust/ Shuttle Valve	Shutoff Valve	Body Material	Const. Ref.
	Pressure to Cylinder	Cylinder to Exhaust				Catalog Number	Catalog Number		
1/8	.7	.8	5	125	125	V043 005	-	Zinc	1
1/4	.8	1.0	5	125	125	V043 006	-	Zinc	1
1/4	.8	1.4	15	150	125	V043 051	-	S.S.	3
1/4	2.0	2.0	5	125	125	V043 001	V043 011	Zinc	2
3/8	3.5	4.5	5	125	125	V043 002	V043 021	Zinc	2

Specifications (Metric units)

Pipe Size (ins.)	Kv Flow Factor (m3/h)		Opening Pressure (bar)	Maximum Operating Pressure Differential (bar)	Max. Air Temp. °C	Quick Exhaust/ Shuttle Valve	Shutoff Valve	Body Material	Const. Ref.
	Pressure to Cylinder	Cylinder to Exhaust				Catalog Number	Catalog Number		
1/8	.60	.69	0.3	8.6	52	V043 005	-	Zinc	1
1/4	.69	.86	0.3	8.6	52	V043 006	-	Zinc	1
1/4	.69	1.20	1.0	10.3	52	V043 051	-	S.S.	3
1/4	1.71	1.71	0.3	8.6	52	V043 001	V043 011	Zinc	2
3/8	3.00	3.86	0.3	8.6	52	V043 002	V043 021	Zinc	2

Dimensions inches (mm)

Const. Ref. 1

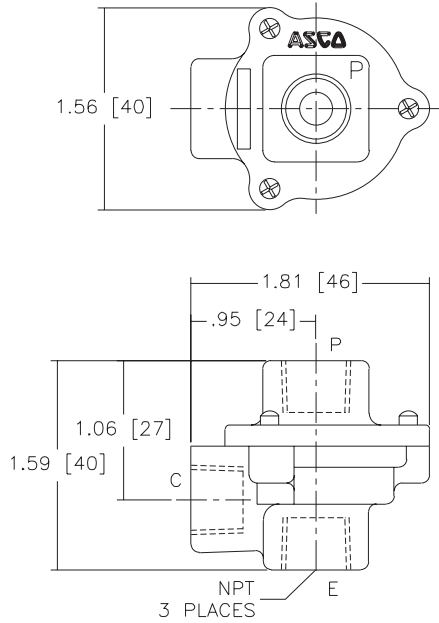

Const. Ref. 2

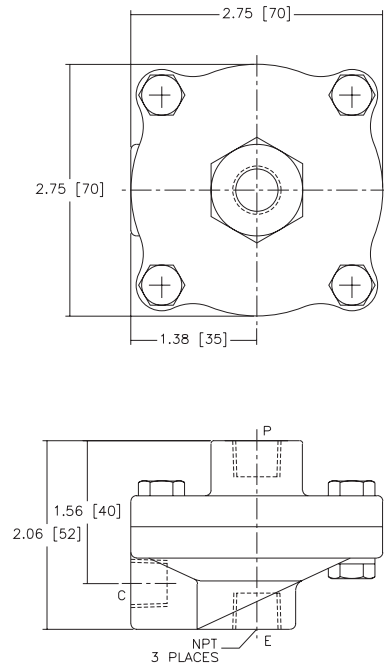

Const. Ref. 3

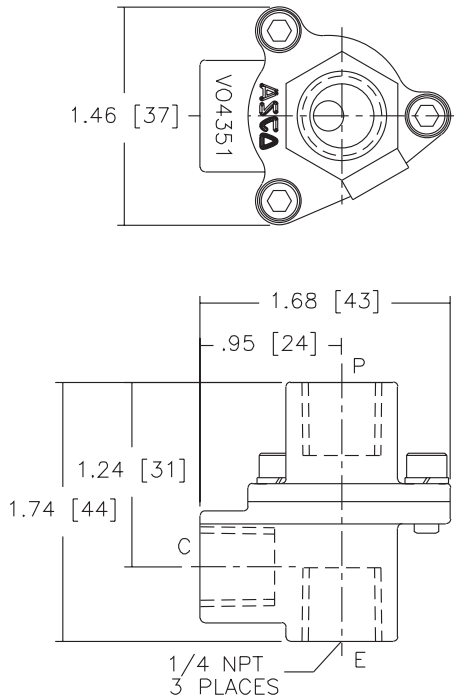

Flow Diagrams

